

T. A. EDISON.
 PRIMARY BATTERY.
 APPLICATION FILED MAY 24, 1910.

1,207,382.

Patented Dec. 5, 1916.
 2 SHEETS—SHEET 1.

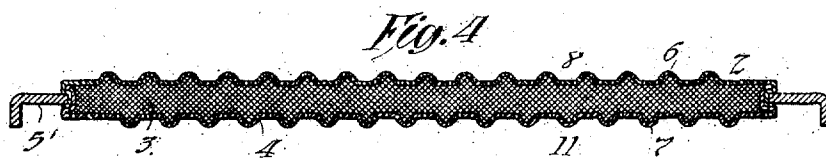
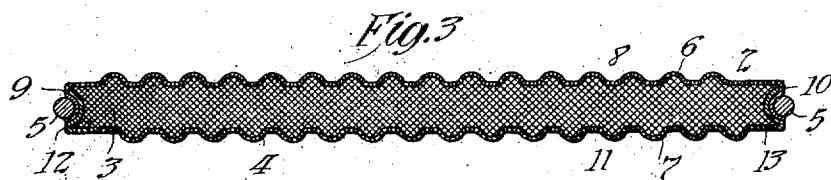
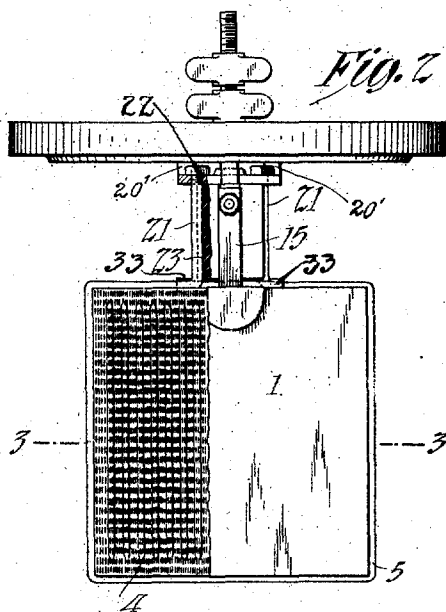
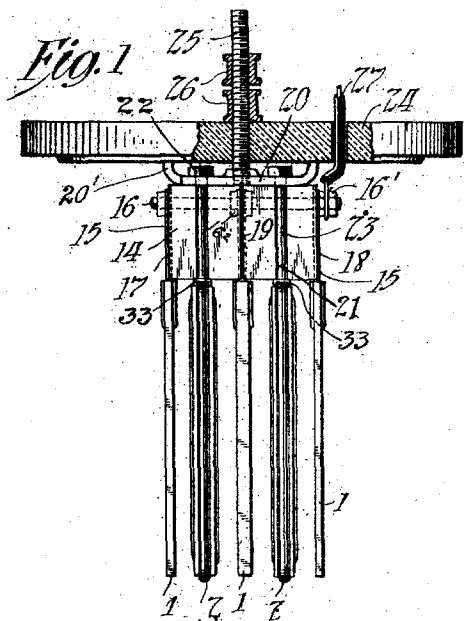

Witnesses:

*Frank D. Lewis
 Dyer Smith*

Inventor:

*Thomas A. Edison
 by Frank L. Lyon
 His Atty.*

T. A. EDISON.
 PRIMARY BATTERY.
 APPLICATION FILED MAY 24, 1910.

1,207,382.

Patented Dec. 5, 1916.
 2 SHEETS—SHEET 2.

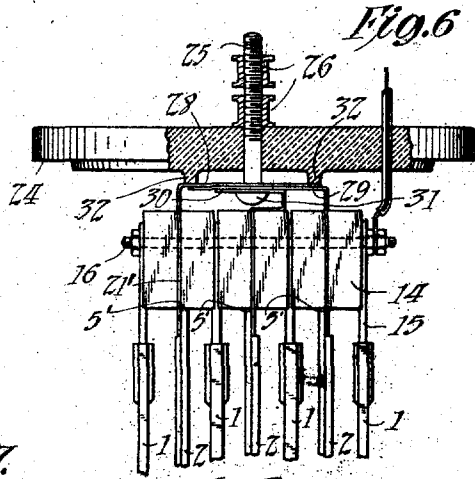
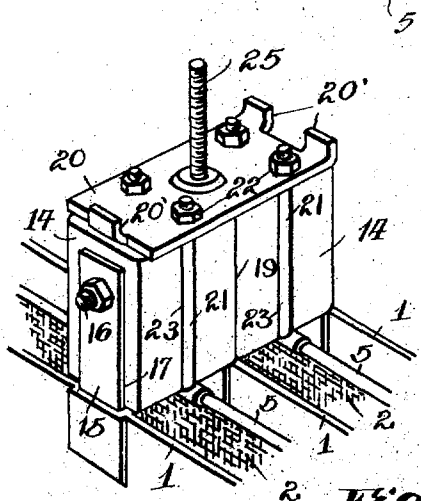
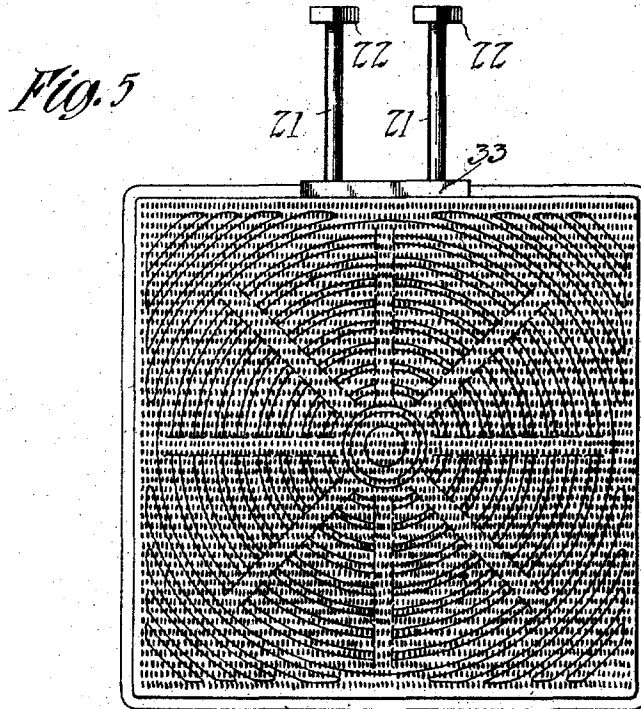

Witnesses:
 Frank D. Lewis
 Dyer Smith

Inventor:
 Thomas A. Edison
 by *Frank L. Brown*
 His Atty.

UNITED STATES PATENT OFFICE.

THOMAS A. EDISON, OF LLEWELLYN PARK, WEST ORANGE, NEW JERSEY, ASSIGNOR TO
NEW JERSEY PATENT COMPANY, OF WEST ORANGE, NEW JERSEY, A CORPORATION
OF NEW JERSEY.

PRIMARY BATTERY.

1,207,382.

Specification of Letters Patent.

Patented Dec. 5, 1916.

Application filed May 24, 1910. Serial No. 563,043.

To all whom it may concern:

Be it known that I, THOMAS A. EDISON, a citizen of the United States, and a resident of Llewellyn Park, West Orange, New Jersey, have invented certain new and useful Improvements in Primary Batteries, of which the following is a description.

My invention relates to improvements in voltaic or primary batteries, and my object is to improve the construction of such batteries both mechanically and electrically, to render practical a "multiple-plate" construction, and particularly to provide a negative electrode plate of novel construction, in which a compressed depolarizing mass is inclosed within a perforated metallic container, which is so constructed as to be practically non-deformable, the electrode thus produced being of great mechanical strength and electrical efficiency.

It has been customary to form negative electrodes by molding plates of copper oxid or other depolarizing agent and a binding material. My improved negative electrode has a number of advantages, both mechanical and electrical, over this construction, as will be hereinafter pointed out. Among these may here be mentioned greater reliability. When a molded plate of copper oxid is used, the latter must be coated with a thin film of metallic copper, and if this becomes oxidized or tarnished, the current produced by the battery will be very weak. To overcome this it has been necessary to short-circuit the cell and thus convert some of the copper oxid upon the surface of the plate into metallic copper. My invention does away with this necessity, since the perforated metallic container in which the depolarizing material is tightly packed under pressure and agglomerated *in situ* performs in a positive and reliable manner the function which was performed by the copper surface upon the molded oxid plate, bringing the copper oxid throughout the container into good metallic contact with the connecting support. Furthermore, my improved cell is superior to one in which the negative electrode consists of a metallic perforated container with a loosely packed mass of copper oxid therein, since the latter furnishes but a weak current on starting up, because a conducting surface of metallic copper must be formed upon the loosely packed oxid particles before the cell can op-

erate efficiently, and because of the poor electrical contact between the particles. In my construction, the oxid is loaded under such pressure that this trouble is obviated.

Another, and one of the chief advantages of my improved construction, is that thereby the negative plate can be made of much less thickness than is practically possible with the molded plate, making practicable the "multiple plate" design or cell. This result is attainable because of the great mechanical strength of the improved plate with its metallic container, and makes it possible to provide a greater extent of surface for the same weight of depolarizing material than was possible under the old practice, without increasing the cubical amount of space occupied by the negative elements in the battery. Accordingly, I may provide a plurality of positive and negative elements in a cell. My improved negative element is preferably given great surface and strengthened by forming the container with corrugations or ribs in any desired manner, the depolarizing mass being so compressed within the same as to form good contact therewith at all points, and to maintain its shape and position under all conditions.

With the objects above mentioned in mind, my invention resides in the improved negative plate as a new article of manufacture, in an effective process for producing the same, and in the details of battery construction hereinafter described and more particularly claimed.

Referring now to the drawings, forming part of this specification, and illustrating preferred forms of construction embodying my invention, Figure 1 illustrates partly in vertical section and partly in end elevation, a plurality of positive and negative elements suspended from the cover of a battery jar; Fig. 2 illustrates a side elevation of the same, parts being broken away to show the construction; Fig. 3 illustrates a section of a negative element as on line 3-3 in Fig. 2; Fig. 4 is a similar section of a negative element showing a slightly modified construction; Fig. 5 illustrates in side elevation a negative element corrugated differently from that shown in Fig. 2; Fig. 6 is a side elevation of a "multiple-plate" cell showing a modified form of supporting device, and Fig. 7 is a perspective view of a

portion of the structure illustrated in Figs. 1 and 2 with the battery jar cover removed.

Referring to the drawings, the battery in its preferred form consists of positive elements 1 of zinc, and negative elements 2 which will be described. As is shown in Fig. 3, the negative element 2 consists of a compressed mass of depolarizing material, preferably copper oxid, 3, incased in a perforated metallic container 4 and surrounded by a metallic frame 5 which rests in contact with the edges of the electrode.

The shell or container 4 of electrode 2 consists of two members 6 and 7, the member 6 comprising a flat top or side portion 8 and turned-over edges 9 and 10, while member 7 comprises a flat side or bottom 11 having turned-up edges 12 and 13. As stated, the top and bottom 8 and 11 of members 6 and 7 are flat, the corrugated form shown in Figs. 3 and 4 being the result of a subsequent operation. Members 6 and 7 fit one within the other, turned-up edges 12 and 13 of member 7 fitting within turned down edges 9 and 10 of member 6.

In forming the electrode 2, a member as 7 is placed within the corresponding member as 6, the edges as 9 and 12 at one end being, however, not turned in. The box-like receptacle thus formed is placed within a former or mold formed to receive the same, the open end of the container being uppermost. Depolarizing material, preferably oxid of copper in granular form, is then dumped into the container through the open upper end in uniform small increments, the copper oxid being, after each increment is added, tamped down by a plunger exerting a very considerable pressure upon the limited area of the copper oxid in the container. A considerable pressure is obtained in this or any other suitable manner, the copper oxid being uniformly packed within the container, which latter is prevented from bulging or becoming deformed during the filling by the former or mold in which it is held.

When the container has been uniformly packed with copper oxid, the open end of the container is closed by bending the edge of member 7 within the edge of member 6, and the loaded container is then fitted into a metallic frame such as the wire 5 shown in Figs. 2 and 3. At the central portion of the upper edge of the loaded container a metallic bridging member 33 is provided which is preferably channel shaped in section with its flanges extending downwardly. The wire 5 is provided with upturned spaced-apart ends 21, 21, which extend through holes in the bridging member 33 near its ends. The ends of the bridging member embrace portions of the wire 5 adjacent the upturned ends 21, 21. The bridging member 33 serves to prevent spreading of the spaced portions of the wire 5. The

plate is then placed within a corrugating die, and subjected to great pressure, preferably hydraulic, whereby the container and inclosed copper oxid are compressed, the container being corrugated or bent by the press in any suitable manner as shown for example in Figs. 3 and 4. The metal frame 5 encircling the edges of the electrode being held in the die against movement, the compression of the electrode results in forcing the material of the container somewhat around the inner edge of frame 5 as shown, flanges 9, 10, 12, 13 of the upper and lower members of the container being thereby curved around frame 5 and secured in locking engagement thereby. The corrugations or ribs formed upon the container by the press have the effect of stiffening and strengthening the same and rendering it practically non-deformable. The mass of copper oxid within the container takes, of course, the same conformation as the container within which it is closely compressed.

If desired, in place of the wire frame 5 surrounding the electrode, a turned-up metal piece 5', as shown in Fig. 4, can be used. The container may be corrugated by the action of the hydraulic press in parallel corrugations or ribs as shown in Figs. 2 and 3, or in any desired manner, as, for example, in concentric and radial lines as indicated in Fig. 5. When the electrode has been formed as described, I prefer to immerse the same in a solution of any suitable binding agent for the copper oxid, as for example, a solution of caustic soda. After the plate has been immersed for a sufficient time in the solution it is removed and dried at moderate heat. The electrode is then ready to be mounted in position in the battery. It is to be noted that in my improved electrode the depolarizing mass is agglomerated *in situ* in its container.

My improved cell may be set up in the manner indicated in Figs. 1 and 2. An insulator 14 of any suitable material, as porcelain, is employed, the positive or zinc elements 1 being suspended below the same by connectors 15, preferably formed of amalgamated copper, or iron plated with copper and amalgamated, through holes in the upper ends of which passes a conducting bolt 16 which is mounted horizontally in the upper portion of insulator 14. If a plurality of elements is used, insulator 14 may be split as shown in the drawings, connectors 15 of the zinc or positive elements then being placed in grooves on the outer edges of the insulator as shown at 17 and 18, and between the contacting faces of the two portions of the split insulator, as shown at 19. A conducting member 20 is placed upon the upper surface of insulator 14 and to this negative elements 2 are connected, the ends 21, 21 of frame 5 surrounding each negative

electrode being bent up as shown and provided with screw threaded ends upon which nuts 22 may be screwed down. The nuts 22 are screwed down so as to clamp the insulator 14 between the conducting member 20 and the bridging member 33. The ends 21 of frame 5 are preferably placed in grooves as 23 upon opposite faces of insulator 14, frame members 21 of negative elements 2 being situated upon the front and back of insulator 14 as shown in the drawings, while connectors 15 of positive elements 1 are located upon the sides of the block 14. Frame members 21 pass through holes in conducting plate 20 upon the top of insulator 14 and are clamped securely in place by nuts 22, the whole then being mounted in the cover 24 of the battery jar by means of a threaded rod or screw 25 passing through the cover 24 and screwing into plate 20 upon the top of insulator 14. Plate 20 may be provided with three or other suitable number of up-turned integral lugs 20' which are drawn into firm contact with the under side of the cover 24 by screw 25 to hold the elements rigidly in position with relation to the cover, or this result may be attained by other means, as by forcing the tops of nuts 22 into firm contact with the under side of cover 24. Nuts 26 are placed upon screw 25 and constitute the positive binding post for the battery, since negative plates 2 are all connected thereby through conducting plate 20. A wire 27 is secured to bolt 16 upon which positive plates 1 are hung, and extends through the cover 24 of the battery jar to form the negative pole of the battery. Nuts 16' upon bolt 16 are screwed tightly to hold together the split insulator and secure plates 1 firmly together. If desired, nuts 16' may be mounted upon bolt 16 on either side of connectors 15 of zinc plates 1 to insure good contact between the zinc plates and bolt 16. The battery jar may now be filled with a suitable electrolyte, as caustic soda solution, and the elements lowered therein, cover 24 resting upon the top of the jar.

In Fig. 6 is shown a seven-plate cell, illustrating a form of support which may be used when the flanged frame 5' surrounding the negative plate is used, as shown in Fig. 4, in place of the wire frame 5 shown in Fig. 3. As shown in Fig. 6, the zinc or positive plates 1, of which the outside ones may be thinner than the intermediate ones, are suspended by connectors 15 from bolt 16 which is mounted horizontally through insulators 14 in the same manner as described in connection with Figs. 1 and 2. Negative elements 2 are supported and connected by thin flat metallic plates 21' which are secured at their lower ends to or are integral with frame members 5' of the negative elements. Plates 21' are clamped between the

split insulators 14 and above the latter are bent horizontally across the top of the insulators and into contact with each other, as shown at 28, 29 and 30. Horizontal portions 28, 29 and 30 of conducting plates 21' are provided with a slot or hole therethrough through which a bolt 25 may be passed and adjusted by nuts 26 above the cover 24 of the battery jar and head 31 below horizontal members 28, 29 and 30, cover 24 preferably being provided on its under side with lugs 32, 32, pressing upon the upper surface of member 28, whereby members 28, 29 and 30 are forced into firm electrical contact with each other.

A cell containing one or more negative electrodes formed in the manner described acts, as has been stated, with greater reliability than a cell in which the oxides are of the molded type. It also has the advantage of greater uniformity, since the oxid-in-closing containers, being machine-loaded, run very uniform in weight and dimensions and therefore have practically identical electrical characteristics. By using a multiple-plate, moreover, I am enabled to realize a much higher capacity in a given size of cell than has heretofore been practicable. At constant temperature the capacity of a given volume of the electrolyte, that is, the quantity of zinc which it will dissolve, depends upon the current rate per square inch of active zinc, or positive electrode, surface. By my invention I am enabled to construct five-plate and seven-plate cells occupying no more space than the former three-plate cells containing one molded oxid plate and two zinc plates. In the five-plate cell the active zinc surface is doubled and in the seven-plate cell it is trebled, in comparison with a three-plate cell having positive and negative plates of the same dimensions, respectively. Furthermore, with the same spacing of plates the internal resistance of the five-plate cell would be about one-half, and of the seven-plate cell, one third that of the three-plate cell mentioned; by my construction, however, the distance between plates may be made considerably less than it is in the present three-plate cell, with consequent further decrease in internal resistance. Also, because of the decreased internal resistance, the working voltage of the "multiple-plate" cells will be much higher than in the old cells at the same discharge rate, or the cells can be discharged at a higher rate while maintaining a voltage at least as high as under the old practice.

Another advantage of my construction is that the connections between the electrodes and the outside circuit are made inside the jar above the level of the electrolyte. The level to which the electrolyte is filled in the jar is below the bolt 16, which result is made possible by the use of the amalgamated cop-

per connectors 15 for the zinc plates 1, which connectors are secured to bolt 16 mounted in the upper part of insulators 14. Where these connections are made below the surface of the electrolyte, electrolytic action tends to take place between the zinc and the copper or iron of the connections.

It may also be noted that in my improved construction the oxid plate is practically integral with its support and thereby the possibility of bad contact between the plate and support is prevented. The plates may be spaced close together without danger of short circuit, because of the rigid support furnished in the improved construction.

Having now described my invention, what I claim and desire to protect by Letters Patent is as follows:

1. As a new article of manufacture, a negative electrode plate for primary batteries comprising a perforated metallic container having a mass of copper oxid agglomerated *in situ* therein and in intimate contact with the walls thereof, substantially as described.

2. As a new article of manufacture, a negative electrode for primary batteries comprising a perforated metallic container having in intimate contact with the walls thereof and agglomerated *in situ* therein a dried mass of copper oxid and binding material, substantially as described.

3. As a new article of manufacture, a negative electrode for primary batteries, comprising a flat perforated metallic container of substantially rectangular cross section and with corrugated walls, having tightly packed therein under pressure and in intimate contact with the walls thereof a dried mass of copper oxid and binding material agglomerated *in situ* in said container, substantially as described.

4. In a primary battery, the combination of a battery jar cover, an insulator, a conducting member supported from the cover below the same and mounted above the insulator, supporting means for said conducting member, an electrode plate below the insulator, a metallic frame surrounding said plate and having end portions engaging opposite sides of said insulator, connected directly to said conducting member and suspending said electrode plate therefrom, a second electrode of opposite polarity to said first named electrode, and a conducting member supported by said insulator to which said electrode is connected and from which it is suspended, substantially as described.

5. In a primary battery, the combination of a plurality of positive electrode plates, conducting connectors extending upwardly therefrom, a conducting rod upon which the upper ends of said connectors are removably secured, a negative electrode plate, means

insulating said plates of opposite polarity from each other, a battery jar cover, and means for suspending said plates from said cover, including a member having upturned lugs in engagement with the under side thereof, substantially as described.

6. In a primary battery, a battery jar cover, a conducting member supported from said cover below the same, a plurality of negative electrode plates, each having upwardly extended spaced apart frame portions secured directly to said conducting member and supported thereby, an insulator supported above each of said negative electrode plates below and in engagement with said conducting member and between and in engagement with said upwardly extended frame portions, and a plurality of positive electrode plates supported from said insulators, substantially as described.

7. The process of forming an electrode plate for primary batteries, which consists in loading and compressing in a perforated metallic container a mass of copper oxid, then impregnating the compressed mass with binding material, and finally drying the same, whereby the material within said container is agglomerated *in situ* therein and in intimate contact with the walls thereof substantially as described.

8. The process of forming an electrode plate for primary batteries, which consists in introducing and tamping a mass of copper oxid in a flat perforated metallic container while preventing deformation of the container, and subsequently subjecting the loaded plate to external pressure upon the sides thereof, then impregnating the compressed mass with binding material, and finally drying the same, whereby the material within said container is agglomerated *in situ* therein and in intimate contact with the walls thereof substantially as described.

9. As a new article of manufacture, an electrode for primary batteries comprising a flat perforated metallic container, a highly compressed mass of copper oxid contained therein and in intimate contact therewith, a frame comprising a wire surrounding the container and contacting the edges thereof except at a portion of the upper edge, said wire having spaced-apart upturned ends adjacent the uncontacted portion of the container edge, and a bridging member connecting said upturned ends in close proximity to said container, substantially as described.

This specification signed and witnessed this 13th day of May, 1910.

THOS. A. EDISON.

Witnesses:

DYER SMITH,

JOHN M. CANFIELD.